

Werkzeugkatalog

tool catalogue

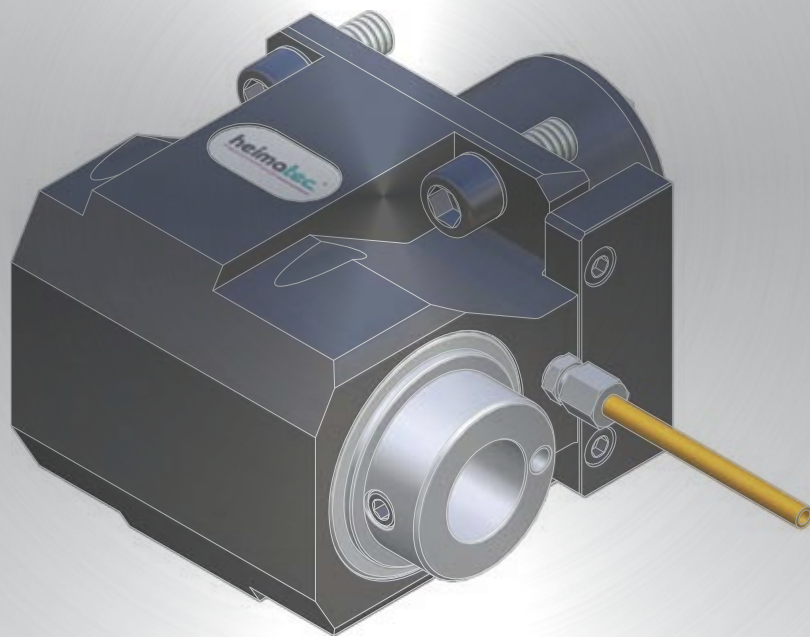

OKUMA

Space Turn LB 2000 EX M/MY

Space Turn LB 2500 EX M

Space Turn LB 3000 EX M/MY



Hinweis zu den AGBs:

Diese finden Sie in unserem Internetauftritt unter

www.heimatec.de

Home/Impressum/AGB

Terms and conditions:

You will find them on our website

www.heimatec.com

Home/Imprint/Terms and Conditions

Das Katalog-Werk einschließlich aller seiner Teile ist urheberrechtlich geschützt. Jede Verwertung außerhalb der engen Grenzen des Urheberrechtsgesetzes ist ohne Zustimmung der Rechteeinhaber unzulässig und strafbar. Das gilt insbesondere für Vervielfältigungen, Übersetzungen, Mikroverfilmungen und die Einspeicherung und Verarbeitung in elektronischen Systemen.

heimatec® GmbH behält sich Änderungen technischer Art jederzeit ohne Vorankündigung vor. Dies gilt insbesondere bei Anpassungen an neue oder geänderte internationale Normen oder bei Weiterentwicklungen unserer Produkte oder Herstellungsprozesse.

This catalogue, including all its parts, is protected by copyright. Each use outside the restricted limitations of the Copyright Act is inadmissible and liable to prosecution without the consent of heimatec. This is particularly valid for duplication, translation, microfilming and feeding and processing in electronic systems.

heimatec® GmbH reserves the right of technical changes everytime without advance notice, which is particularly valid for adaptations to new or changed international standards, or to developments of our products or manufacturing processes.

angetriebene Werkzeuge
driven tools



Axial-Bohr- und Fräskopf
axial drilling and milling head

$n_{max} = 6000 \text{ min}^{-1}$

8 010 66 071	ER 32 AX u-tec	EK	1:1
8 010 66 072	ER 32 AX u-tec	IK 25 bar	1:1
8 010 66 073	ER 32 AX u-tec	IK 70 bar	1:1
8 010 67 033	easy quick HT 5	EK	1:1
8 010 67 034	easy quick HT 5	IK 25 bar	1:1
8 010 67 075	easy quick HT 5	IK 70 bar	1:1



Winkel-Bohr- und Fräskopf
radial drilling and milling head

Mittenmaß / center distance $H=70$
 $n_{max} = 6000 \text{ min}^{-1}$

8 030 66 088	ER 32 AX u-tec	EK	1:1
8 030 66 085	ER 32 AX u-tec	IK 140 bar	1:1
8 030 67 038	easy quick HT 5	EK	1:1
8 030 67 039	easy quick HT 5	IK 140 bar	1:1



Winkel-Bohr- und Fräskopf
radial drilling and milling head

Mittenmaß / center distance $H=70$
 $n_{max} = 3000 \text{ min}^{-1}$

Drehrichtung beachten ! / note rotating direction !

8 030 66 091	ER 32 AX u-tec	EK	2:1
--------------	----------------	----	-----



Schwenkkopf
universal head

Mittenmaß / center distance $H=70$
 $n_{max} = 6000 \text{ min}^{-1}$

8 040 64 013	ER 16 AX u-tec	EK	1:1
--------------	----------------	----	-----



Schwenkkopf
universal head

Mittenmaß / center distance $H=70$
Achsversatz / offset
 $n_{max} = 6000 \text{ min}^{-1}$

8 043 64 001	ER 16 AX u-tec	EK	1:1
--------------	----------------	----	-----

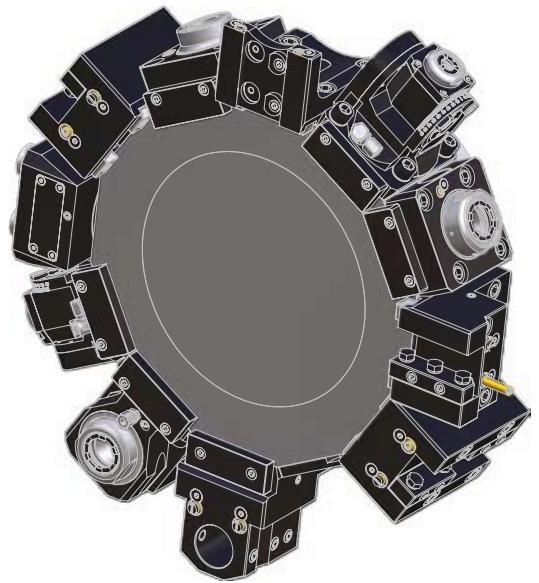

Scheibenfräserkopf
disk mill head

$\pm 10^\circ$ drehbar
 $\pm 10^\circ$ turnable

Mittenmaß / center distance $H=87,5$
auf 0° absteckbar / 0° can be pinned
kein Kühlmittel / no coolant
 $n_{max} = 3000 \text{ min}^{-1}$

8 037 65 009	$\varnothing 25,4 (1'')$	2:1
8 037 65 010	$\varnothing 22$	2:1



Mehrspindelbohrkopf
multi spindle drilling head

$n_{max} = 6000 \text{ min}^{-1}$

8 050 64 002	ER 20 AX u-tec	EK	1:1
Achsversatz / offset $A=75$			
8 053 64 000	ER 20 AX u-tec	EK	1:1
Achsversatz / offset $A=80$			

festе Werkzeuge
static tool holders

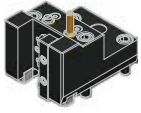

Kombi-Drehstahlhalter
universal turning holder

- | | | |
|--------------|----------------------------------|----|
| 8 224 05 001 | Vierkant/square 25 | EK |
| 8 224 05 004 | Vierkant/square 25,4 (1") | EK |



Kombi-Plandrehhalter
combi facing holder

- | | | |
|--------------|----------------------------------|----|
| 8 244 05 001 | Vierkant/square 25 | EK |
| 8 244 05 004 | Vierkant/square 25,4 (1") | EK |



Bohrstangenhalter
boring bar holder

Mittenmaß / center distance H=90

- | | | |
|--------------|------------------------|-------|
| 8 240 08 001 | ∅ 32 | IK/EK |
| 8 240 09 007 | ∅ 40 | IK/EK |
| 8 240 08 006 | ∅ 31,75 (1,25") | IK/EK |
| 8 240 08 007 | ∅ 38,1 (1,5 ") | IK/EK |



Abstechhalter
cut-off holder

- | | | |
|--------------|--------------|----|
| 8 224 03 000 | SH 32 | EK |
|--------------|--------------|----|

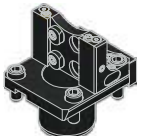

Abstechhalter
cut-off holder

- | | | |
|--------------|--------------|----|
| 8 224 03 001 | SH 32 | EK |
|--------------|--------------|----|

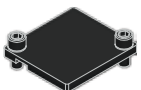

Abdeckplatte
cover plate

- | | | |
|--------------|--|--|
| 8 200 63 000 | | |
|--------------|--|--|

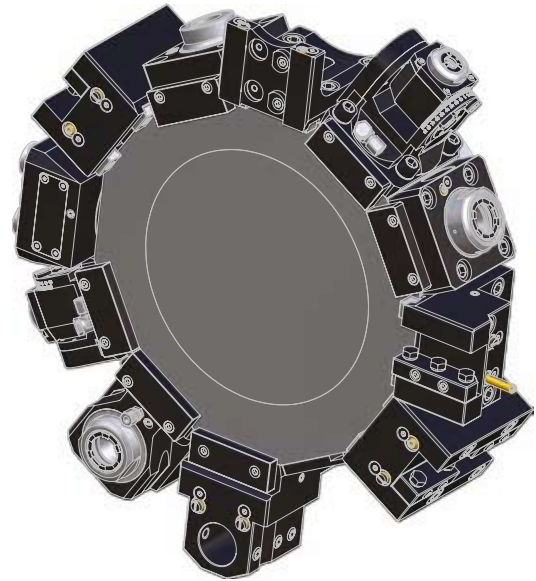

OKUMA Space Turn LB 2000 EX M/MY - LB 2500 EX M - LB 3000 EX M/MY

▶ Weitere Ausführungen auf Anfrage
further versions on request

▶ Zubehör **ZB...***
accessories **ZB...***



▶ **easy-quick**



▶ **u-tec**



Hauptsitz/headquarters

heimatec® GmbH
Präzisionswerkzeuge
Carl-Benz-Straße 4
D- 77871 Renchen
Postfach 11 36
D- 77867 Renchen
Tel.: +49 (78 43) 94 66 0
Fax: +49 (78 43) 94 66 66
www.heimatec.de
info@heimatec.de

heimatec® Inc.
16 E. Piper Lane Suite 121
USA- 60070 Prospect Heights IL
Tel.: +1 (847) 749 0633
Fax: +1 (847) 749 2445
www.heimatecinc.com
info@heimatecinc.com

heimatec® - Ost, JSC
ul. Kozjubinskogo 4 office 209
RUS- 121351 Moskau
Tel.: +7 (495) 648 69 19
Fax: +7 (495) 648 69 19
www.heimatec-ost.ru
sales@heimatec-ost.ru

